

ISO 13254 Thermoplastics Piping Systems for Non-Pressure Applications – Test Method for Watertightness/ Testing Equipment

Description

2 Principle

A test assembly comprising either a fabricated product or an assembly of pipes and/or fittings is subjected to a given internal hydrostatic pressure for a given time period during which the leaktightness of the fabricated product or the joint is verified by inspection.

NOTE It is assumed that the following test parameters are set by the referring standard:

- a) the sampling procedure (see 4.1 and Clause 5);
- b) the number of test pieces (see 4.2).

3 Apparatus

3.1 End-sealing devices, having a size and using a sealing method that are appropriate to the type of joint assembly under test. The devices shall be restrained in such a manner that does not exert longitudinal forces on the joint assembly and prevents the devices or the assembly under test from separating under pressure.

The mass of the devices shall not be permitted to influence the angular deflection to be applied (see 5.2).

3.2 Hydrostatic pressure source, connected to one end of at least one end-sealing device, capable of applying the required pressure gradually and evenly in accordance with 5.4, and then of keeping it constant to within $(+2\% \text{ to } -1\%)$ for the required duration of test (see Clause 5).

3.3 Bleed valve, capable of venting air when the hydrostatic pressure is applied to the test piece.

3.4 Pressure-measuring device, capable of checking conformity to the required test pressure (see 3.2 and Clause 5).

4 Test pieces

4.1 Preparation of test pieces

The test piece shall comprise either a fabricated fitting or an assembly of (a) pipe section(s) (with or without sockets) and/or fitting(s), including at least one joint of the type under test (see Figure 1).

To assist air removal, the test pieces may be inclined by up to 12° .

Dimensions in millimetres

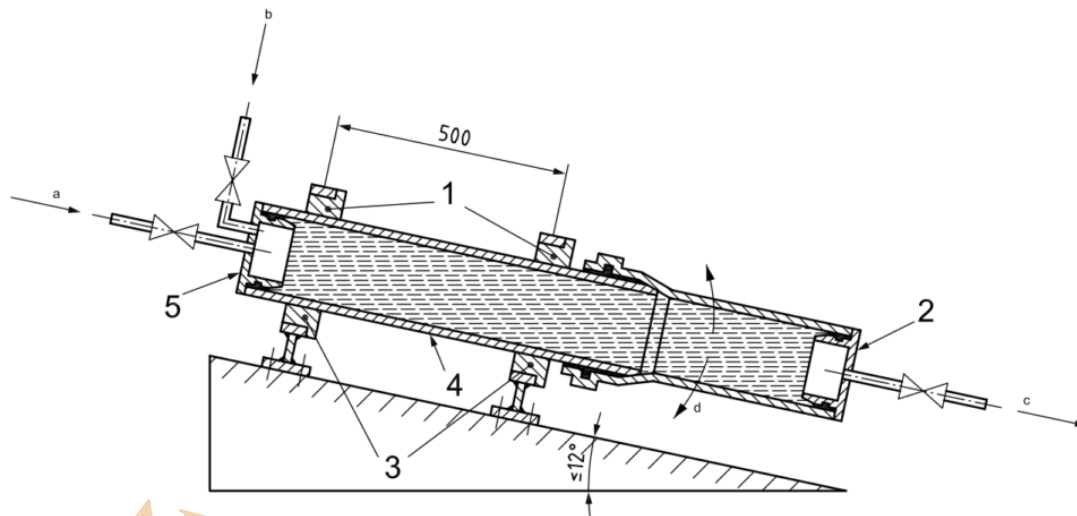
**Key**

- 1 fixed points
 - 2 sealing plug with water outlet and end restraint (see 3.1)
 - 3 loose bushes enabling all sizes of pipes to be accommodated on the same test fixture
 - 4 fixed component
 - 5 sealing plug with water inlet, air outlet and end restraint
- a Water inlet.
 - b Air outlet.
 - c Water outlet.
 - d Direction of movement for angular deflection, if applicable (see 5.2).

Figure 1 — Typical arrangement

The assembly of the joint(s) shall be carried out in accordance with the manufacturer's instructions. The assembly shall comprise the combination of the smallest available spigot end and the largest available socket or socket groove diameter within the applicable tolerance(s) and obtained by sampling in accordance with the referring standard. The relevant diameters of the selected spigots and sockets shall be measured and recorded.

4.2 Number of test pieces

The number of test pieces shall be specified in the referring standard.

5 Procedure

5.1 Carry out the following procedure at a temperature of $(23 \pm 5) \text{ }^\circ\text{C}$ using cold tap water, without permitting any condensation to form on the surface of the test piece.

5.2 Mount the test piece in the apparatus. If the joint to be tested permits angular deflection, arrange the

test assembly such that the joint(s) under test is (are) subject to its (their) maximum angular deflection, as stated by the manufacturer for the specific joint, with regard to the axes of the components thus joined.

5.3 When testing in accordance with 5.4 and 5.5, monitor the test piece for, and record any evidence of, leakage.

5.4 Introduce water into the test piece, while bleeding off all air, and apply the hydrostatic pressure in

the following manner:

- a) accelerated procedure for fabricated products: unless otherwise specified in the referring standard, apply an hydrostatic pressure of 0,5 bar¹) and maintain it for at least 1 min;
 - b) for assemblies of pipes and/or fittings which are not fabricated: raise the hydrostatic pressure smoothly over a time period not greater than 15 min to 0,5 bar and maintain that pressure for at least 15 min.
- 5.5 Depressurize, drain and dismantle the test piece. Inspect for and record any changes in the appearance of the components tested.

6 Test report

The test report shall include the following information:

- a) a reference to this International Standard, i.e. ISO 13254:2010, and the referring standard;
- b) the complete identification of the components (e.g. fittings, pipes, assemblies) comprising the joints under test and their respective diameters, in millimetres (see 4.1);
- c) the test temperature (see 5.1), in degrees Celsius;
- d) the test pressure, in bar;
- e) the time period under pressure, in minutes;
- f) the angle of deflection applied to the joint, if applicable (see 5.2);
- g) a statement that the joint did not leak or, if applicable, a report of the signs of leakage or rupture, their position(s) and the pressure at which they occurred;
- h) any change in the appearance of the components of the test piece(s) during testing or immediately afterwards;
- i) any factor that could have affected the results, such as any incident or any operating details not specified in this International Standard;
- j) the date of the test.



Watertightness Tester According to ISO 13254 (Computerized)

- Slope of setup assembly less than 12°
- Specimen filling pump
- End caps are based on customer request
- Windows based software included

- Computer is included
- Test pressure up to 1 bar
- Graphing of data and exporting of report to MS WORD
- Automatic pressure rate control
- Compressed air input
- Cover of sample (Plexiglass door) is as option
- ERGO arm for assembly of monitor
- 7/24 online distance support

Watertightness Tester According to ISO 13254 (Manual)

- Slope of setup assembly less than 12°
- Specimen filling pump
- Manual valve for pressure control
- End caps are based on customer request
- Test pressure up to 1 bar
- Digital display of pressure
- Compressed air input
- Cover of sample (Plexiglass door) is as option

Category

1. Equipment for Standards
2. Standards