

DIN EN ISO 13846 – End-load-bearing and Non-end-load-bearing Assemblies and Joints for Thermoplastics Pressure Piping – Test Method for Long-term Leaktightness Under Internal Water Pressure – Testing Equipment

Description

2 Principle

The test simulates expansion of the joint area due to creep. This is related to the permissible working conditions for 50 years and based on the properties of the components assembled.

The leaktightness of the joint(s) is tested as an assembly comprising either:

- a) at least one fitting joined to pipes; or
- b) an ancillary component or a valve joined to pipes; or
- c) a pipe-to-pipe joint.

The test is carried out for at least 1000 h at ambient temperature and at the maximum allowed working temperature for the piping system for which the assembly or joint is intended to be used.

The test piece and its joint(s) are subjected to a specified internal hydrostatic water pressure at a specified temperature for the period of time (1000 h or more) specified in the referring standard.

Additional reinforcement of the joint area is not permitted for this test.

NOTE It is assumed that the following test parameters are set by the standard making reference to this standard:

- a) the minimum test period under pressure, i.e. 1000 h or more (see clause 2 and 5.4);
- b) the free length, L, of the pipe sections under test (see 4.1);
- C) the number of test pieces (see 4.2);
- d) the test temperature (e.g. ambient or maximum allowed working temperature) (see 5.2);
- e) the test pressure (see 5.3).

3 Apparatus

3.1 Ambient temperatures

For tests at ambient temperatures (see 5.2), a test room or water bath, capable of being maintained at a temperature to within $\pm 2^{\circ}\text{C}$.

3.2 Elevated temperatures

For tests at elevated temperatures, an air chamber or water bath, capable of being maintained at the specified test temperature to within $(+3/-1)^{\circ}\text{C}$.

3.3 Pressure control device

A pressure control device connected to the test assembly and capable of applying a constant hydrostatic pressure to within $(+2/-1)\%$.

3.4 Support

Support for end-load-bearing assemblies and joints such that the assemblies and joints shall be subjected to the axial forces generated during the test and such that the support shall not provide any axial restraint. (For bibliography see EN 715) An example of solvent cement type test assembly is shown in figure 1.

3.5 Compensating device

A compensating device for non-end-load-bearing assemblies and joints, capable of sustaining the axial forces generated by the internal water pressure, whilst maintaining the axial alignment of the joint assembly. (For bibliography see EN 714[2].) Connecting rods or external frames between non-endload bearing sealing devices to keep them in place as necessary to prevent any separation. Examples of test assemblies are shown in figures 2 and 3.

NOTE Precautions can be necessary to maintain the alignment of the joint assemblies, particularly for removal of the test assemblies from the test bath.

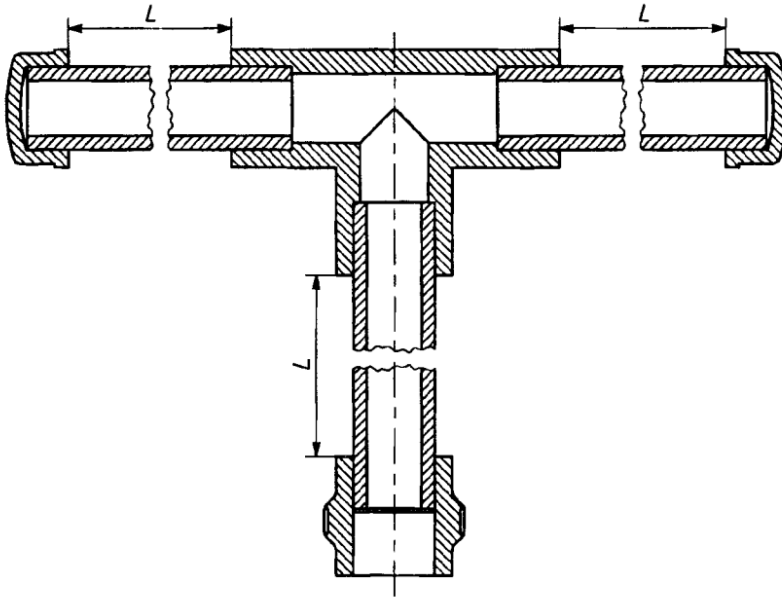

Figure 1 — Example of solvent cement type test assembly

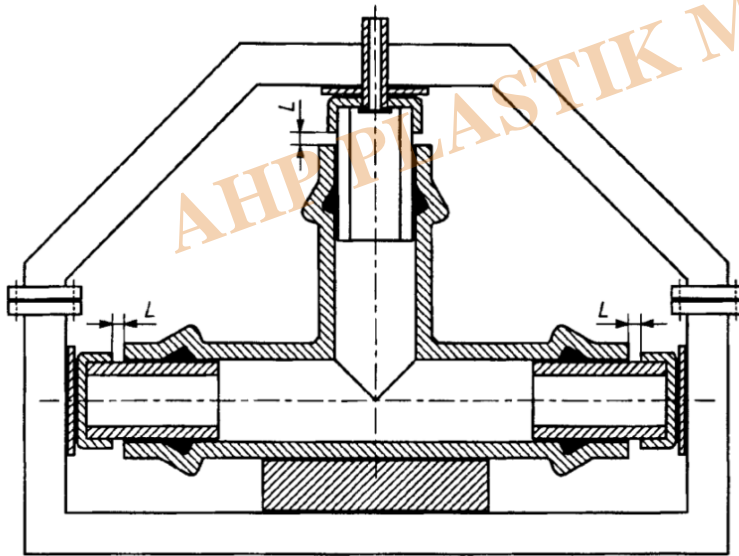

Figure 2 — Example of elastomeric sealing ring type test assembly

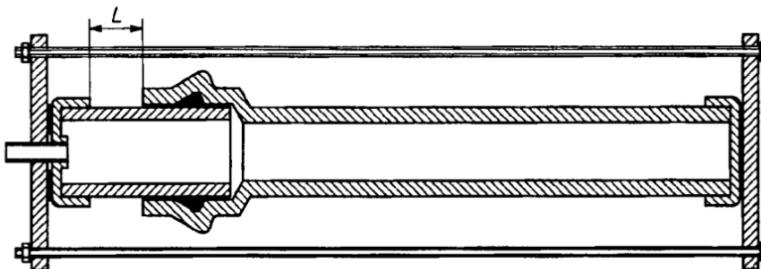

Figure 3 — Example of integral joint type test assembly

4 Test piece

4.1 Preparation

The test piece shall comprise an assembly containing at least one pipe sample joined to a socket of a fitting or to a socketed pipe or joined with an assembled finished product (such as a valve or union). Additional components may be added to the test assembly as required.

Components of the same nominal pressure, PN, or the same pipe series S, shall be used for the assembly.

The relevant dimensions of the joint components shall be measured and recorded, i.e. the mean outside diameter and out-of-roundness of any spigot or pipe joint area, the mean inside diameter and out-of-roundness of any socket and the relevant dimensions of any intermediate component (see note at the end of this clause).

The minimum length of the pipe section shall be such that its free length, L, between the assembly under test and the joint or the end closure (plug or cap) shall be as specified in the referring standard.

NOTE If the free length is not specified in the referring standard, it should be not less than the nominal outside diameter of the pipe,, with a minimum of 150 mm.

All components shall conform to the appropriate part of the applicable System Standard. In addition the elastomeric sealing rings shall conform to the manufacturer's specifications.

The assembly shall be carried out in accordance with the manufacturer's instructions. For non-end-load-bearing joints connecting rods or external frames may be used as necessary to prevent any separation (see 3.5).

NOTE For this test components should be selected which are as near as possible to the extremes of their respective tolerance bands which provide the most severe test conditions, e.g. for elastomeric sealing ring joints the socket and the diameter of the ring groove housing should be at or as near as possible to their maximum value, the spigot of the pipe or fitting should be at or as near as possible to the minimum value, and the sealing ring should be at or as near as possible to the minimum cross-section specified by the manufacturer.

5 Procedure

WARNING All necessary precautions should be taken when testing using components under pressure.

5.1 Preparation

Fill the test assembly with water. Set up the test assembly, without any deformation, in the apparatus appropriate to the type of joint and adjust the pipe section(s) in line with the axis (axes) of the

socket(s)-

5.2 Conditioning

Condition the test assembly in the test room or conditioning chamber for at least 3 h for test temperatures more than 25 °C or for at least 20 min for test temperatures equal to or less than 25 °C. If the test temperature is specified as “ambient temperature”, carry out the conditioning at any temperature between 15 °C and 25 °C. During subsequent testing in accordance with 5.3 to 5.5 inclusive, maintain the test temperature constant to within ± 2 °C and within the range of 15 °C to 25 °C.

5.3 Pressure control

Connect the test assembly to the pressure control device. Evacuate all air from the test assembly and within the period 30 s to 1 min apply the test pressure as specified in the referring standard.

Record the time when the test pressure is achieved as the commencement of the test period.

Inspect the assembly for any signs of leakage and report the result.

5.4 Examination of the test assembly

When required (see 5.5), inspect the test assembly, as appropriate, as follows.

a) If the test is carried out in air, thoroughly dry the whole outside surface of the test piece and examine it for leakage.

b) If the test is carried out in water, remove the test assembly from the test bath, dry the surface of the test piece, examine it for leakage and if leakage is not observed, return the test assembly to the bath as soon as possible.

5.5 Examination at the mid-point and at the end of the test period Repeat the examination of the test assembly for leakage (see 5.4) at the mid-point and at the end of the test period, which shall be at least 1000 h, unless a longer minimum period is specified in the referring standard or prior failure of the assembly occurs in a manner which does not allow continuation in accordance with 5.6.

5.6 Rupture

If rupture occurs in the pipe section between the joints under test or in an end closure not included as part of the test assembly, disregard the test and replace the failed component by another. After replacement, continue the test procedure. If the failure of the component causes damage to any of the joints or assemblies on test, reject these test pieces and repeat the test procedure.

Category

1. Equipment for Standards
2. Standards